



# PRÜFTECHNIK

## OPTALIGN smart RS5

### Технические характеристики

По вопросам продаж и поддержки обращайтесь:

Архангельск (8182)63-90-72	Калининград (4012)72-03-81	Нижний Новгород (831)429-08-12	Смоленск (4812)29-41-54
Астана +7(7172)727-132	Калуга (4842)92-23-67	Новокузнецк (3843)20-46-81	Сочи (862)225-72-31
Белгород (4722)40-23-64	Кемерово (3842)65-04-62	Новосибирск (383)227-86-73	Ставрополь (8652)20-65-13
Брянск (4832)59-03-52	Киров (8332)68-02-04	Орел (4862)44-53-42	Тверь (4822)63-31-35
Владивосток (423)249-28-31	Краснодар (861)203-40-90	Оренбург (3532)37-68-04	Томск (3822)98-41-53
Волгоград (844)278-03-48	Красноярск (391)204-63-61	Пенза (8412)22-31-16	Тула (4872)74-02-29
Вологда (8172)26-41-59	Курск (4712)77-13-04	Пермь (342)205-81-47	Тюмень (3452)66-21-18
Воронеж (473)204-51-73	Липецк (4742)52-20-81	Ростов-на-Дону (863)308-18-15	Ульяновск (8422)24-23-59
Екатеринбург (343)384-55-89	Магнитогорск (3519)55-03-13	Рязань (4912)46-61-64	Уфа (347)229-48-12
Иваново (4932)77-34-06	Москва (495)268-04-70	Самара (846)206-03-16	Челябинск (351)202-03-61
Ижевск (3412)26-03-58	Мурманск (8152)59-64-93	Санкт-Петербург (812)309-46-40	Череповец (8202)49-02-64
Казань (843)206-01-48	Набережные Челны (8552)20-53-41	Саратов (845)249-38-78	Ярославль (4852)69-52-93

# Faster and smarter shaft alignment

with OPTALIGN® smart RS5 technology

## The measurement principle

OPTALIGN® smart RS5 uses a single laser and a 5-axis sensor. The sensor contains two fully-linearized biaxial position detectors and a precision inclinometer. It can precisely measure relative shaft movement in five degrees of freedom. This measurement principle is the only one which allows 'Live Move' with concurrent monitoring of the vertical and horizontal machine corrections and with the sensor at any angular position.

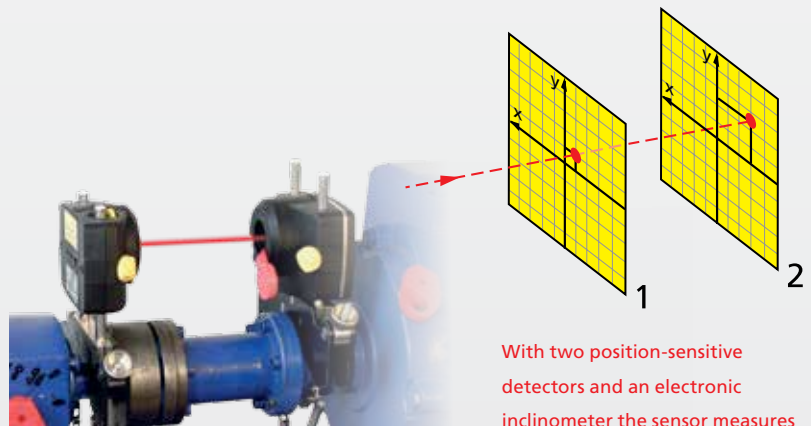

With two position-sensitive detectors and an electronic inclinometer the sensor measures the exact position of the laser beam as the shafts are rotated.

## The SWEEP measurement mode

With this exclusive and patented measurement mode, data is automatically and continuously collected as the shafts are rotated. During shaft rotation, a large number of measurement points are captured to accurately determine the alignment condition. Measurement can start at any position and in any direction.



## Concurrent Live Move

Monitor the machine corrections concurrently in both horizontal and vertical directions with laser and sensor mounted at any angular position on the shaft.

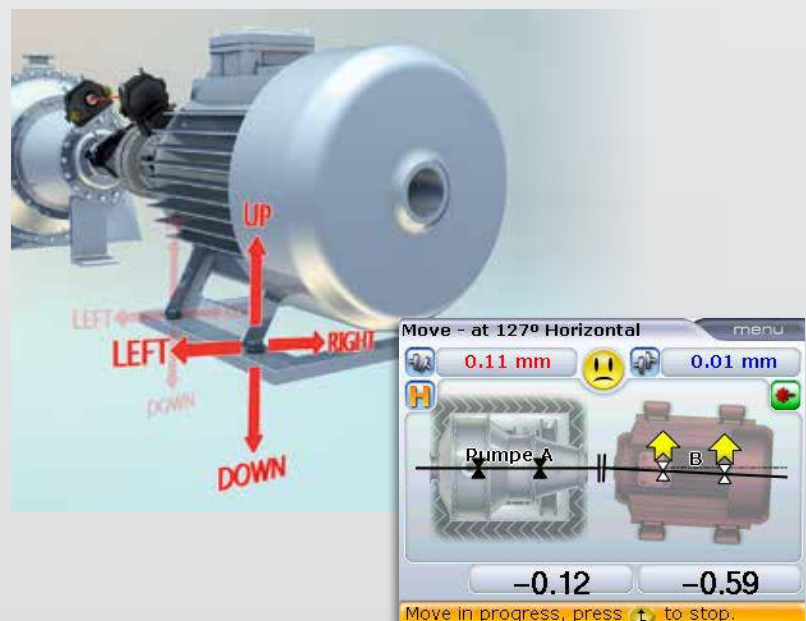

OPTALIGN® smart RS5 is packed with powerful functions for the alignment of horizontal, vertical and flange-mounted machines. The system has been designed for industrial applications and can be used in extreme maintenance working conditions.

### 3 keys to precision alignment

The main function keys allow a quick switch between the main functions during the alignment.

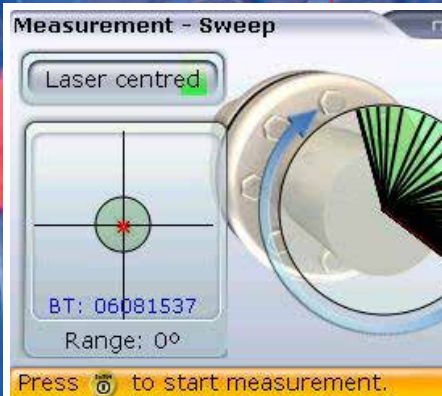

db PRÜFTECHNIK

Machine A to B dimensions

[mm]

RPM 1500

Pump A

Motor B

Ø100

Distance from sensor to coupling center

OPTALIGN® smart RS

Type: ALL15200 S.No.: 15200001

# Machine shaft alignment with a twist

Only three steps to the perfect alignment

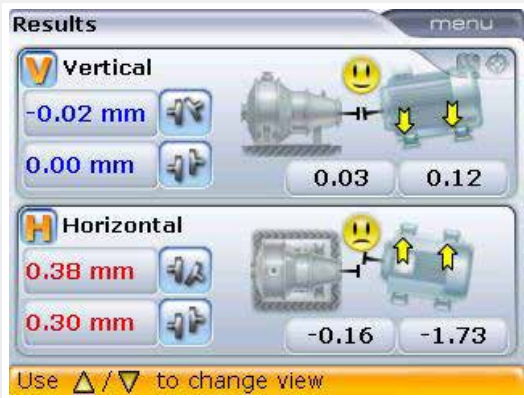

## Laser / Sensor

The OPTALIGN® smart RS5 measurement principle is based on the patented single laser beam technology which uses one laser and a sensor including two biaxial position detectors and an electronic inclinometer.

## Computer

The OPTALIGN® smart RS5 computer features a high resolution TFT colour display for clear information readability even in unfavourable light conditions. The computer is operated by disposable or Li-Ion rechargeable batteries. The USB interface enables easy connection to a PC and other peripheral devices such as a printer.

## Operation and user interface

The alphanumeric keyboard and the navigation keys ensure comfortable operation of the measurement system. With the context menu the user can easily access all required options. The status line text provides valuable guidance for beginners. The alignment results are clearly displayed in graphic and digital formats.

## ▶ Bluetooth® communication

Convenient and flexible wireless data transmission.

## ▶ SWEEP measurement mode

Automatic collection of alignment data during shaft rotation.

## ▶ Concurrent Live Move

Monitor the machine corrections in both horizontal and vertical directions with laser and sensor at any angular position on the shaft.

## ▶ Single laser technology

Patented single laser/sensor technology for easy set-up.

## ▶ InfiniRange®

This function extends the detector surface, making it possible to measure machines with severe angular misalignment or distant from each other. Rough alignment is not necessary, and the initial alignment condition is recorded and documented.

## ▶ Intuitive user guidance

The system guides the user step-by-step to determine the machinery alignment condition and its tolerance evaluation.

## ▶ Flip machines

Swap the position of the machines e.g. motor and pump, together with machine dimensions.

## ▶ Automatic evaluation of alignment

The Smiley and LED provide visual indication of the alignment condition and a live status update during machine correction.

## ▶ Soft foot check

Measure, correct and save results.

## ▶ File management

Save measurement files in the device or transfer reports as PDF to a USB memory stick.

## ▶ Data protection

Auto save and resume capability.

# OPTALIGN® smart RS5 powerful features

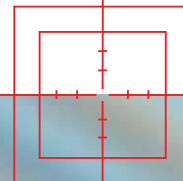

## Standard features

Bluetooth® integrated
Live Move – concurrently monitors horizontal and vertical corrections
Alignment of horizontal, vertical and flange-mounted machines
Alignment of coupled, uncoupled and non rotatable shafts
Fixed feet selection – resolves base-bound or bolt-bound problems
Soft foot check – measure, correct and save results
Automatic continuous measurement as shaft is rotated – start and stop rotation at any position
Automatic evaluation of alignment condition with TolChek® and user-defined tolerances
Results table to verify measurement repeatability
Flip machines to swap the position of the machines e.g. motor and pump
InfiniRange® extends detector measurement range to handle any amount of misalignment
Checking the effects of pipe strain on machine
Static measurement mode – requires any 3 of the 8 available 45° measurement positions
Save reports as PDF directly to a USB stick
Data protection – auto save and resume capability

## Powerful options

3-machine train alignment
Enter alignment targets and thermal growth values including input of dial indicator readings
2D straightness application
Multipoint mode – measurement at any 3 or more positions over 60° rotation or more
Alignment of cardan and spacer shafts
Heavy-duty rechargeable Li-Ion battery
Our alignment software to manage measurement files and create reports

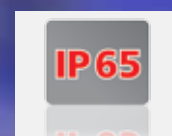

# OPTALIGN® smart RS5 technical data

<b>RSS BT sensor</b>	
Type	5-axis sensor: 2 planes (4 displacement axes and angle) Measurement area: unlimited, dynamically extendible (U.S. Patent 6,040,903) Resolution: 1 µm (0.04 mil) and angular 10 µRad Accuracy (avg): > 98% Measurement rate: approx. 20 Hz
Inclinometer	Resolution: 0.1° Error: 0.3% full scale
LED indicators	1 LED for laser adjustment and battery status 1 LED for Bluetooth communication
Power supply	Lithium-Ion rechargeable battery: 3.7 V / 5 Wh Operating time: 10 hours (continuous use) Charging time: Using charger – 2.5 h for up to 90%; 3.5 h for up to 100% Using USB port – 3 h for up to 90%; 4 h for up to 100%
External interface	Integrated Bluetooth 4.1 Smart Ready wireless communication USB 2.0 Full Speed
Transmission distance	Up to 30 m [98 ft] direct line of sight
Environmental protection	IP 65 (dustproof and water jets resistant), shockproof Relative humidity: 10% to 90%
Ambient light protection	Yes
Temperature range	Operation: -10°C to 50°C [14 °F to 122°F] Storage: -20°C to 60°C [-4°F to 140°F] Charging: 0°C to 40°C [32°F to 104°F]
Dimensions	Approx. 105 x 74 x 58 mm [4 9/64" x 2 29/32" x 2 1/4"]
Weight	Approx. 235 g [8 1/3 oz.]
CE conformity	Refer to the CE compliance certificate in <a href="http://www.pruftechnik.com">www.pruftechnik.com</a>
<b>Laser</b>	
Type	Semiconductor laser diode
Beam divergence	0.3 mrad
Beam power	< 1 mW
Wavelength	630 – 680 nm (red, visible)
Safety class	The laser complies with 21 CFR 1040.10 and 1040.11 except for deviations pursuant to Laser Notice No. 50, dated June 24, 2007.
Safety precautions	Do not look into laser beam
Power supply	Batteries 2 x 1.5 V IEC LR6 ("AA") Operating time: 180 hours
Environmental protection	IP 65 (dustproof and water jets resistant), shockproof Relative humidity: 10% to 90%
Temperature range	Operation: -10°C to 50°C [14°F to 122°F] Storage: -20°C to 60°C [-4°F to 140°F]
Dimensions	Approx 105 x 74 x 47 mm [4 9/64" x 2 29/32" x 1 27/32"]
Weight	Approx. 225 g [7 15/16 oz.]
CE conformity	Refer to the CE compliance certificate in <a href="http://www.pruftechnik.com">www.pruftechnik.com</a>

<b>Computer</b>	
CPU	Marvell XScale PXA270 running at 520 MHz
Memory	64 MB RAM, 64 MB Flash
Display	Type: TFT, transmissive (sunlight-readable), 65 535 colours, backlit LED Resolution: 320 x 240 Pixel Dimensions: 3.5 inch (89 mm) diagonal Keyboard elements: Navigation cursor cross with up, clear and menu keys; Alphanumeric keyboard with dimensions, measure and results hard keys
LED indicators	4 LEDs for laser status and alignment condition 2 LEDs for wireless communication and battery status
Power supply	Disposable batteries: 6 x 1.5 V IEC LR6 ("AA") Lithium-Ion rechargeable battery: 7.4 V / 2.5 Ah / 18.5 Wh (optional) Operating time: 18 hours typical use (based upon an operating cycle of 25% measurement, 25% computation and 50% 'sleep' mode)
External interface	USB host USB slave RS232 (serial) for sensor Integrated wireless communication, class 1, transmitting power 100 mW AC adapter/charger socket
Environmental protection	IP 65 (dustproof and water jets resistant), shockproof Relative humidity: 10% to 90%
Temperature range	Operation: -10°C to 50°C [14 °F to 122°F] Storage: -20°C to 60°C [-4°F to 140°F] Charging: 0°C to 40°C [32°F to 104°F]
Dimensions	Approx. 214 x 116 x 64 mm [8 7/16" x 4 7/16" x 2 1/2"]
Weight	865 g [1.9 lb]
CE conformity	Refer to the CE compliance certificate in <a href="http://www.pruftechnik.com">www.pruftechnik.com</a>
<b>Carrying case</b>	
Standard	ABS, drop tested 2 m [6 1/2 ft]
Dimensions	Approx. 480 x 400 x 195 mm [18 5/64" x 15 47/64" x 7 43/64"]
Weight	Including all standard parts: approx. 8.3 kg [18.3 lb.]

## Services and customer support

- ▶ Alignment high-tech lab
- ▶ Customized product training
- ▶ Machinery service – worldwide
- ▶ Calibration and repair





# PRÜFTECHNIK

По вопросам продаж и поддержки обращайтесь:

Архангельск (8182)63-90-72	Калининград (4012)72-03-81	Нижний Новгород (831)429-08-12	Смоленск (4812)29-41-54
Астана +7(7172)727-132	Калуга (4842)92-23-67	Новокузнецк (3843)20-46-81	Сочи (862)225-72-31
Белгород (4722)40-23-64	Кемерово (3842)65-04-62	Новосибирск (383)227-86-73	Ставрополь (8652)20-65-13
Брянск (4832)59-03-52	Киров (8332)68-02-04	Орел (4862)44-53-42	Тверь (4822)63-31-35
Владивосток (423)249-28-31	Краснодар (861)203-40-90	Оренбург (3532)37-68-04	Томск (3822)98-41-53
Волгоград (844)278-03-48	Красноярск (391)204-63-61	Пенза (8412)22-31-16	Тула (4872)74-02-29
Вологда (8172)26-41-59	Курск (4712)77-13-04	Пермь (342)205-81-47	Тюмень (3452)66-21-18
Воронеж (473)204-51-73	Липецк (4742)52-20-81	Ростов-на-Дону (863)308-18-15	Ульяновск (8422)24-23-59
Екатеринбург (343)384-55-89	Магнитогорск (3519)55-03-13	Рязань (4912)46-61-64	Уфа (347)229-48-12
Иваново (4932)77-34-06	Москва (495)268-04-70	Самара (846)206-03-16	Челябинск (351)202-03-61
Ижевск (3412)26-03-58	Мурманск (8152)59-64-93	Санкт-Петербург (812)309-46-40	Череповец (8202)49-02-64
Казань (843)206-01-48	Набережные Челны (8552)20-53-41	Саратов (845)249-38-78	Ярославль (4852)69-52-93